

The **Quick Response Team** at DEL Liftgates stands ready to provide you with fast action when you need service, parts or technical assistance. Call our customer service department at 1-800-289-1335 Monday - Friday, 8:00 a.m. to 5:00 p.m., or reach us 7 days a week through our internet home page.

Use this space to insert your liftgate reference numbers for easy access.

Serial #
Model #

Quick Response *TEAM*



WARNING

Improper operation of this liftgate may result in severe personal injury or death. **DO NOT** operate this liftgate without proper instruction and a complete understanding of the procedures in this manual.

Introduction

Thank you for purchasing a DEL Liftgate. Your liftgate is an example of the finest engineering in the industry and, with proper care and operation, will serve your needs for years. Not only have you purchased one of our liftgates; we feel you have entered into a partnership with us.

To begin our partnership we welcome you to the DEL Liftgates Team and assure you your continuous satisfaction with our product is most important to us. Our **Quick Response TEAM** at DEL Liftgates stands ready to provide you with fast action when you need sales, parts, or technical assistance. You can call our customer service department Monday - Friday 8 a.m. to 5 p.m. Eastern Time or reach us 24 hours a day, 7 days a week through our internet home page or voice message system. Providing quality, value, and service to our customers is what our business is all about.

Read this manual carefully to learn how to operate and care for your liftgate properly. Maintenance (other than the simple routines we ask you to perform within this manual), inspections, and repairs must be completed by a **DEL Liftgate Authorized Service Center only**. If you do not know who the Authorized Service Center in your area is, please contact us at:

DEL Liftgates, Inc.

P. O. Box 6126
190 Lewis Street
Buffalo, NY 14240-6126
Phone: (800) 289-1335 or (716) 853-7994
Fax: (716) 854-5424
<http://www.liftgate.com>

Table of Contents

Description	Page
<u>Introduction</u>	1
<u>Table of Contents</u>	2
<u>Scope of this Manual</u>	4
<u>Description of DL Series Liftgates</u>	6
<u>Theory of Operation</u>	7
<u>Design Detail</u>	8
<u>Special Features</u>	10
<u>Limits of Operation & Use</u>	11
<u>Abnormal & Unsafe Practices</u>	13
<u>Safety</u>	14
<u>Activating Liftgate</u>	17
<u>Normal Operating Procedures</u>	
Opening the Platform	
Snap Lock Design	18
Drop-In Style Travel Plate Design	19

Table of Contents

Proper Cargo Loading Procedures

Preferred Method	22
Single Operator Method	26

Closing and Storing Platform	30
------------------------------------	----

<u>Deactivating Liftgate</u>	32
------------------------------------	----

Dock Loading Procedures

Truck bed is even with loading dock	33
Loading dock is higher than truck bed	37
Loading dock is lower than truck bed	40

Preventive Maintenance

Essential Maintenance Inspections	44
Daily Overall Inspection	45
Sample Daily Chart	47

<u>Liftgate Warranty Procedure</u>	48
--	----

<u>Getting Help</u>	49
---------------------------	----

<u>Ordering Parts</u>	50
-----------------------------	----

Scope Of This Manual

DEL Liftgates, Inc. has designed this manual to illustrate the steps needed for the basic operation of our Rail Series liftgates. It also provides safety information and simple preventive maintenance tips.

NOTE: This manual is not intended for use as a repair or troubleshooting guide.

This manual has been designed to use in conjunction with the **DL/PT/SB/TG Rail Series liftgates only**. These are rail style liftgates ranging in capacities from 1250 lb. up to and including 3000 lb. capacity. To determine the type of liftgate you have:

- 1) *Refer to the serial number tag on the liftgate. The area labeled "Model Number" (see page 5 of this manual) will have a "DL" denotation in the prefix of the model number if it is a DL series liftgate;*
- 2) *Ask your employer or lessor;*
- 3) *Call your Authorized Service Center for assistance;*
- 4) *Call us for assistance at 1-800-289-1335. You can also contact us by fax, 716-854-5424, or visit our home page at www.liftgate.com*

If you are experiencing difficulty or are in need of repair, contact the DEL Liftgates Factory for information on the experienced and trained DEL Liftgates Authorized Service Center in your area.

Free manuals are available, call 1-800-289-1335 & order part # 20659.

Scope Of This Manual

Model Number

The code and model number of a liftgate are references to its size, type and capacity.

DL 20 95 36 AF
1 2 3 4 5



1. Liftgate type

DL = Rail Style Liftgate
PT = Pickup Rail Style Liftgate
SB = Service Body Rail Style
Liftgate
TG = Tool Gate Rail Style Liftgate

2. Weight capacity

10 = 1000 lb. capacity
12 = 1250 lb. capacity
16 = 1600 lb. capacity
20 = 2000 lb. capacity
30 = 3000 lb. capacity

3. Width of liftgate

(from outside of rail to outside of rail)

95 = 95" overall width

4. Depth of Platform

(not including ramp)

36 = 36" of platform loading area

5. Standard floor height or above the floor lift

TML, ML, AF, M = Above floor

T = Standard liftgate

Blank = Standard liftgate

DL Series Liftgate Description

The DL Series liftgate is a *100% level ride*, rail-style liftgate. This style liftgate is available in a range of capacities from 1250 lb. up to and including 3000 lb. Rail-style liftgates have two rails mounted to the rear of your truck, either by welding or by bolting. These rails support the platform on which you raise your cargo.

Depending on what type of DL Series liftgate you have, it may or may not lift above the floor of your truck. Models that will lift above the truck floor will have one of the following denotations at the end of the model number:

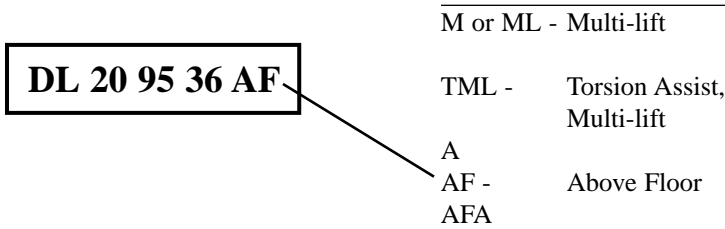

The last denotation, AF, is the most current used to indicate above floor lift. This began in October of 1993. (If there is no denotation at the end of the model number, it is a standard liftgate, with **no** above floor lift capability.)

Important Safety Features

- Pressure compensated flow valve
- Treadplate platform
- Toe Guard in housing cover
- Platform locks (safety locks)
- Warning decals and manuals

Theory of Operation

The rail type liftgate is designed to lift cargo vertically from the truck bed to the ground or dock, and vice-versa. Power is provided by a hydraulic power unit and cylinder that activates a chain and sprocket system. Activation of a control switch supplies current from a 12 volt battery to the hydraulic power unit. The hydraulic power unit in turn supplies pressurized hydraulic fluid to the hydraulic cylinder. The cylinder extends, tensioning the chains which are attached to the platform. The resultant upward pull on the platform raises it.

The platform is lowered by gravity. Activation of the control switch releases the hydraulic fluid back to the power unit from the cylinder. The cylinder retracts releasing the tension in the chain and the platform lowers by its own weight.

Design Detail

This is a drawing of a DL Series liftgate with descriptions of the common parts.

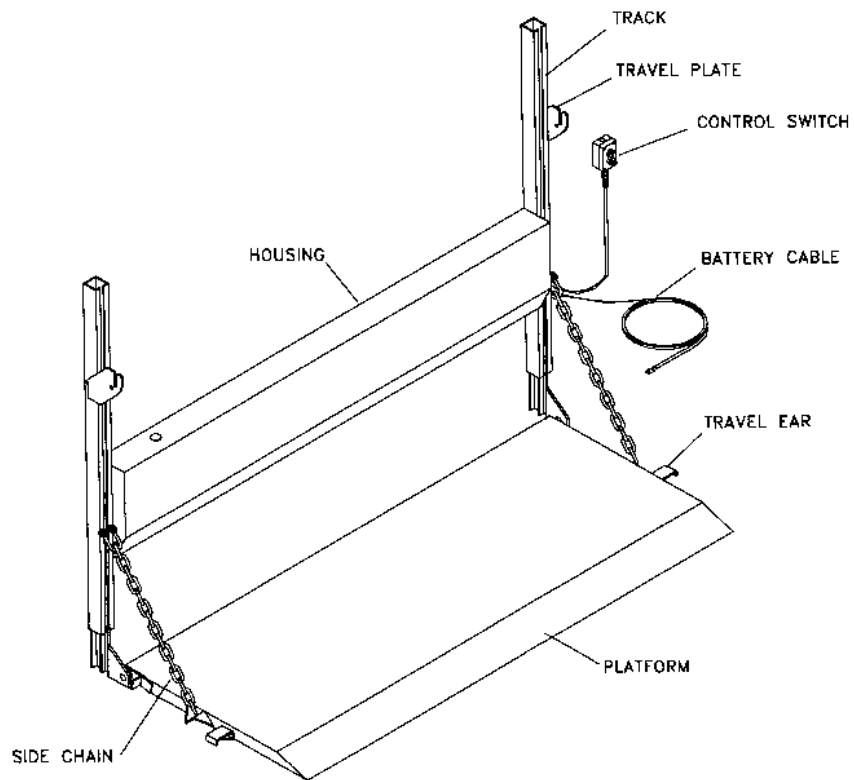

DL Operator
Rev. 03/00

Design Detail

This is a general drawing of the power system for most DL style liftgates.

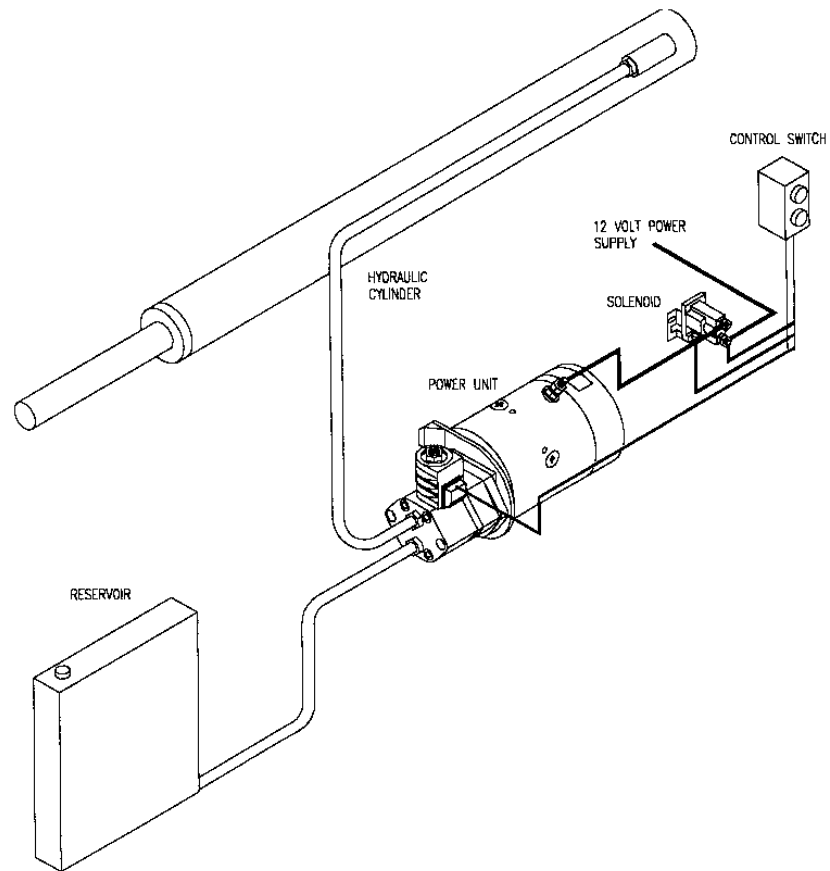

Special Features

We have developed the new low maintenance features for our lift-gates by listening to you - our customers. Our low maintenance lift-gates are value engineered to reduce maintenance cost and downtime while increasing productivity. Our special features include:

Maintenance Free Bushings at all major hinge points - These bushings replace grease fittings that were traditionally high maintenance items. The new bushing significantly reduce maintenance cost and downtime.

Rubber Sealed Push Button Control - In order to help prevent freezing and obstacles from jamming the control buttons, all liftgates feature a control switch with rubber sealed push buttons.

Pressure Compensated Flow Control Valve - This valve ensures that the platform descent is controlled at any load capacity or in the event of a damaged hydraulic hose.

We are always interested in hearing your comments and suggestions especially to improve our products, please contact us at **1-800-289-1335** or our internet page anytime. If we are not there leave a message and we will get back to you as soon as possible.

Limits of Operation & Use

SAFETY INSTRUCTIONS

Before operating liftgate be sure to understand these instructions:

1. Improper operation of this lift can result in serious personal injury. **DO NOT OPERATE** unless you have been properly instructed and have read, and are familiar with, the operating instructions. If you do not have a copy of the instructions please obtain them from your employer, distributor, or lessor, as appropriate, before you attempt to operate the lift.
2. Be certain the vehicle is properly and securely braked before using the lift.
3. Always inspect this lift for maintenance or damage before using it. If there are signs of improper maintenance, damage to vital parts, or slippery platform surface, do not use the lift. **DO NOT** attempt your own repairs, unless you are specifically trained.
4. **DO NOT OVERLOAD.** See Maximum Capacity Decal for the rated load. Remember that this limit applies to both raising and lowering operations.
5. Each load should be placed in a stable position as near as possible to the **CENTER** of the platform.

Limits of Operation & Use

SAFETY INSTRUCTIONS

6. Keep people clear of liftgate while operating. **NEVER STAND** in or move through or allow anyone else to stand in or move through the area in which the liftgate may operate or into which the unstable load may fall.
7. **DO NOT RIDE** the liftgate. This is **NOT** a passenger lift. Unstable loads or failure of the liftgate would endanger you. *This liftgate is not equipped with a back-up system to prevent the liftgate from falling in the event of a failure.*
8. Ensure all decals are legible and in their correct locations. If you require replacement decals contact **DEL Liftgates, Inc.** Read all safety decals before operating the liftgate.

Abnormal & Unsafe Practices



WARNING

Improper use of the liftgate may result in severe damage to liftgate and/or severe personal injury or death. Never use liftgate for anything other than its designed use of loading/unloading cargo.

The following are unsafe practices that may cause hidden damage to the liftgate creating the risk of serious personal injury or death:

- Using the liftgate as a jack
- Using the liftgate to pull, push, or tow objects
- Using force of the hydraulic system to bend, shear, or break objects
- Using the liftgate to plow snow
- Driving a forklift over the liftgate
- Driving the truck with platform open
- Pulling the platform open from the support chains
- Pulling the platform closed from inside truck by the support chains

The following unsafe practices may result in serious personal injury or death:

- Riding the liftgate
- Using the platform as a step into the truck bed

Safety

DANGER, WARNING, and CAUTION are “signal words” that identify the level of risk or hazard involved in an operation or step. The signal word will accompany a “SAFETY ALERT SYMBOL.”



Immediate hazards which WILL result in severe personal injury or death.	 DANGER
--	---

Hazards or unsafe practices which COULD result in severe personal injury or death.	 WARNING
---	--

Hazards or unsafe practices which COULD result in minor personal injury or product or property damage.	 CAUTION
---	--

Safety

Operate Safely

- ⇨ Run liftgate through a full cycle before operating every day; inspect liftgate for missing or loosened fasteners, broken welds, signs of overload and that side chains are well secured; and check that all decals are in their proper place and legible.
- ⇨ Clear area of any objects that may be pinched or crushed. Keep people out of work area. Stop operating liftgate if anyone enters the area.
- ⇨ If you hit anything with the liftgate - STOP immediately! Remove object and inspect damage. Make any repairs before you operate liftgate again.
- ⇨ DO NOT leave liftgate activated or platform open when unattended.
- ⇨ DO NOT allow an untrained person to operate the liftgate.

Help Prevent Serious Injury Or Fatal Accidents

- ⇨ DO NOT ride the liftgate at anytime or use platform when it is not on the ground as a step into the truck. Riders risk the chance of falling off the liftgate.
- ⇨ Disconnect power to the liftgate when it is unattended or once it is in the stored position.

Safety

- ⇨ DO NOT run a forklift or other heavy machinery onto the platform at anytime.
- ⇨ DO NOT use the liftgate for any other reason than loading or unloading cargo.
- ⇨ DO NOT operate the liftgate if you are under the influence of drugs or alcohol.

Loading And Unloading Safely

- ⇨ Be sure to operate liftgate on a level surface.
- ⇨ When backing truck up to loading dock, do not hit the dock. Have a second person outside the truck directing you.

Using The Control Switch

- ⇨ DO NOT depress the “UP” button for any longer than necessary to perform the desired function. Release the button immediately once the platform reaches its full height. Failure to release button immediately may cause damage to liftgate components causing the liftgate to fail unexpectedly.
- ⇨ DO NOT “jerk” the liftgate by pressing the “Up/Down” buttons too quickly. The sudden movement may cause the cargo to become unstable and/ or fall.

Activating Liftgate

To provide power to the liftgate;



WARNING

Improper operation of this liftgate may result in serious injury or death. DO NOT operate this liftgate without being properly instructed and understanding this manual.

Using the 135 AMP Circuit Breaker:

Step 1

“SLIDE” the Reset Lever **UPWARDS** until it snaps into position.

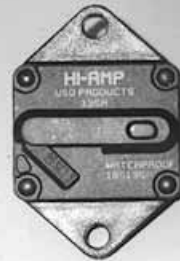

Using the Master Disconnect Switch:

Step 1

“TURN” the knob to the **ON** position.



Normal Operating Procedures

Opening Liftgate Platform;

NOTICE: There are *two* types of locks. Either the *Snap Lock Design* or the *Drop In Style Travel Plates* will be on your liftgate. Use the steps pertaining to your specific liftgate lock.

Snap Lock Design:



WARNING

Platform may crush or pinch. Keep people clear of liftgate while operating.



Step 1

On models equipped with the Snap Lock Design, you must first remove the safety pin. Once removed, pull lever down until the top of the lock clears the travel ear.



Step 2

Continue holding lever down while using the grab handle to pull the platform towards you.

Normal Operating Procedures

Drop In Travel Plate Design:



⚠ WARNING

Platform may crush or pinch. Keep people clear of liftgate while operating.

Step 1

On models equipped with the Drop In Design, align travel ear with vertical opening of drop in plate by pulling on grab handle and releasing lock.



Step 2

Continue holding handle while pressing “UP” button on the two button switch located on the outside of the truck to raise the platform until travel ear clears the drop-in plate.



Normal Operating Procedures

Opening Platform Continued:



Step 3

Carefully lower the platform to its horizontal position.



Step 4

Press the "DOWN" button on the two button switch located on the outside of the truck to lower the platform to the ground.

Step 5

Begin loading the truck. See "Proper Cargo Handling Procedures" under **Normal Operating Procedures (pages 21-29)**.

Normal Operating Procedures

Proper Cargo Handling Procedures;

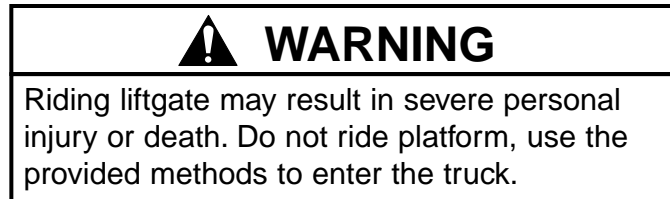

To avoid riding the liftgate, two operating procedure methods have been designed to fit your particular situation. They are as follows:

Preferred Method: With this method, you will have an operator and an assistant to load and unload the truck. The operator is on the ground loading and the assistant is inside the truck unloading,

Single Operator Method: With this method, you will only use one operator to load and unload the truck. This procedure requires you to have two switches; one mounted inside the truck and one mounted outside the truck.

(Contact the DEL Liftgate Factory if you do not have a second switch.)

Normal Operating Procedures

Proper Cargo Handling Procedures;

Preferred Method:



WARNING

Platform may crush or pinch. Keep people clear of liftgate when operating.

Step 1

Open the platform. See “Opening Liftgate Platform” under **Normal Operating Procedures (Pages 18-20)**.



Step 2

With platform on the ground, the assistant enters the truck by using the provided methods.

Normal Operating Procedures

CAUTION

Cargo placed near the edge of the platform may fall and/or cause excessive wear to the lifting components. Place cargo in the center of the platform to reduce risk of falling and evenly distribute cargo weight.

Step 3

The operator loads the platform, placing cargo in the center and making sure it is stable. Secure load to prevent cargo from falling while platform is moving.



CAUTION

Depressing the “UP” button too long may result in personal injury & damage lifting components. Release button immediately once stopped.

Step 4

The operator raises the platform to the bed of the truck by pressing the “UP” button on the two button switch located on the outside of the truck.



Normal Operating Procedures



Step 5

The assistant now unloads cargo from platform into the truck.



Step 6

Once complete, the assistant advises the operator to lower platform to the ground.



Step 7

Once use of the liftgate is complete, with the platform on the ground, the assistant climbs out of the truck using the provided method.

Normal Operating Procedures

Step 8

Place the platform in its stored position. See
“Closing and Storing” under **Normal
Operating Procedures (pages 30-31)**.

Normal Operating Procedures

Proper Cargo Handling Procedures;

Single Operator Method:



WARNING

Platform may crush or pinch. Keep people clear of liftgate while operating.

Step 1

Open the platform. See “Opening Liftgate Platform” under **Normal Operating Procedures (Pages 18-20)**.

Normal Operating Procedures

WARNING

Cargo placed near the edge of platform may fall and/or cause excessive wear to the lifting components. Place cargo in center to reduce risk of falling and to evenly distribute the weight.

Step 2

With platform on the ground, begin loading. Place cargo in the center and make sure it is stable. Secure load to help prevent cargo from falling while platform is moving.



WARNING

Riding liftgate may result in severe personal injury or death. Do not ride platform, use the provided methods to enter the truck.

Step 3

Climb into the truck using the provided methods.



Normal Operating Procedures

CAUTION

Depressing the “UP” button too long may result in personal injury & damage lifting components. Release button immediately once stopped.



Step 4

Once inside, raise the platform to the bed of truck by pressing “UP” button on the two button switch located on the **inside** of the truck.



Step 5

Unload the cargo into the truck.

Normal Operating Procedures

Step 6

When unloading is complete, lower platform to ground by pressing the “DOWN” button on the two button switch on the **inside** of the truck.



Step 7

With platform on the ground, climb out of the truck using the provided methods.



Step 8

Once use of the liftgate is complete, place the platform in its stored position. See “Closing and Storing” under **Normal Operating Procedures (pages 30-31)**.

Normal Operating Procedures

Closing and Storing the Platform;

Remember: Use appropriate steps pertaining to your specific lock.



WARNING

Platform may crush or pinch. Keep people clear of liftgate while operating.



Step 1

To prepare for travel, raise platform to a comfortable lifting position and lift to its vertical position.

Snap Lock Design:



Step 2

Use the “Up/Down” buttons on the two button switch to adjust platform until the travel ear can be placed into the snap lock with the jaw closed around it.

Normal Operating Procedures

Step 3

Once lock is in place, reinsert the safety pin.



Drop In Travel Plate Design:



Step 2

Press the “UP” button to raise the platform so the ear of the lock clears the travel plate. Once cleared, press the “DOWN” button so the travel ear drops into the travel plate.



Deactivating Liftgate

To disconnect power to the liftgate;

WARNING

Unauthorized use may result in severe personal injury or death. Deactivate liftgate when finished operating.

Using the 135 AMP Circuit Breaker:



Step 1

“PUSH” Red Button **IN** until the reset lever is fully open.

Using the Master Disconnect Switch:



Step 1

“TURN” the knob to the **OFF** position.

Normal Operating Procedures

Proper Dock Loading Procedures;

Truck bed is even with loading dock:

(NOTICE: A second person will need to be outside to direct the driver.)



WARNING

Platform may crush or pinch. Keep people clear of liftgate when operating.

Step 1

With platform in its stored position, carefully align the truck and back up towards the dock. Stop truck about 3-4 feet from dock.



Step 2

Remove platform from **Stored Position**. See “Opening Platform” under **Normal Operating Procedures (pages 18-20)**.

Normal Operating Procedures



Step 3

Lower platform (vertical position) by pressing the “DOWN” button on the two button switch located on the outside of the truck until the platform 5-6” from the ground.



Step 4

Secure lowered platform with a load lock strap to prevent platform from opening.

CAUTION

Do not move truck with platform on the ground.
Liftgate may be torn off or severely damaged.



Step 5

Back truck to within 4-6 inches of dock and if necessary, lower platform until the top of platform is below bed of the truck.

Normal Operating Procedures

WARNING

Do not run forklift over platform. Serious hidden damage to liftgate may result in sudden failure and personal injury or death.

Step 6

Place dock plate (if necessary) across loading dock and bed of the truck. (Dock plate acts as a bridge.) Once in place, begin loading/unloading the truck.



WARNING

Do not move truck with platform on the ground. Liftgate may be torn off or be severely damaged.

Step 7

Once loading/unloading is complete, remove dock plate (if necessary). Before moving truck, raise the platform 5-6" by pressing the "UP" button on the two button switch on the outside of the truck.



Normal Operating Procedures



Step 8

Move truck about 3-4 feet away from dock.

Step 9

Once use of the liftgate is complete, return it to its stored position. See “Closing and Storing” under **Normal Operating Procedures** (pages 30-31).

Normal Operating Procedures

Proper Dock Loading Procedures;



WARNING

Incorrectly following these steps may result in severe personal injury or death. Before beginning the Dock Loading Procedures be sure to follow the **Proper Cargo Handling Steps (pages 21 - 29)** which apply to you.

Loading dock is higher than bed of truck:

(Above floor model liftgates only)

(NOTICE: A second person will need to be outside to direct the driver.)



WARNING

Platform may crush or pinch. Keep people clear of liftgate while operating.

Step 1

Open the platform. See “Opening Platform” under **Normal Operating Procedures (pages 18-20)**.

Normal Operating Procedures



Step 2

With the platform at truck bed height slowly back truck towards the dock. **STOP** once the platform is within 1-3” of the dock. (Do not hit dock with truck or platform.)



Step 3

Unload cargo from **truck** to **liftgate** platform.

 CAUTION
Depressing the “UP” button too long may result in personal injury & damage lifting components. Release button immediately once stopped.



Step 4

Raise platform to dock. Place dock plate across the platform, if it is needed, to act as a bridge.

Normal Operating Procedures

 **WARNING**

Do not run forklift over platform. Serious hidden damage to liftgate may result in sudden failure and personal injury or death.

Step 5

Unload cargo from **platform** to **dock** and lower platform to bed of the truck.



Step 6

Once use of the liftgate is complete, return to its stored position. See “Closing and Storing” under **Normal Operating Procedures** (pages 30-31).

Normal Operating Procedures

Proper Dock Loading Procedures;

 WARNING
Incorrectly following these steps may result in severe personal injury or death. Before beginning the Dock Loading Procedures be sure to follow the Proper Cargo Handling Steps (pages 21 - 29) which apply to you.

Loading dock is lower than bed of truck:

(NOTICE: A second person will need to be outside to direct the driver.)

 WARNING
Platform may crush or pinch. Keep people clear of liftgate while operating.

<p>Step 1 Open the platform. See “Opening Platform” under Normal Operating Procedures (pages 18-20).</p>

Normal Operating Procedures

Step 2

Raise platform above dock height.



Step 3

Back truck up so the entire platform is over the dock. (**DO NOT** hit dock with truck or platform.)



Step 4

Lower platform until it rests on dock.



Normal Operating Procedures

WARNING

Do not run forklift over platform. Serious hidden damage to liftgate may result in sudden failure and personal injury or death.



Step 5

You may begin loading the platform.



Step 6

Once full, raise the loaded platform to the bed of the truck.

Normal Operating Procedures

Step 7
Unload cargo to the truck.



Step 8
Once use of the liftgate is complete, return it to its stored position. See “Closing and Storing” under **Normal Operating Procedures** (pages 30-31).

Preventive Maintenance

Essential Maintenance Inspections;

We strongly recommend using our preventive maintenance schedule to keep your liftgate running at its best. The *Daily Inspection* should be performed by you the operator, each day. The *Routine Maintenance Schedule* should be performed periodically by a DEL Liftgate Authorized Service Center. By performing your *Daily Inspection* and having *Routine Maintenance Inspections* you can ensure years of safe, trouble free operations.

Your first visit to your DEL Liftgate Authorized Service Center should occur once the liftgate has been in operation for 30 days. During this break in period slight misalignment may occur. The importance of this initial inspection is to help the liftgate maintain a level ride and keep the platform traveling freely during any operation. Once this is complete, use the chart below as a guide to schedule your liftgate for its routine maintenance inspections:

Cycles Per Day	Operations Performed		
	LOWERING RATED LOAD & LIFTING EMPTY PLATFORM	LIFTING 1/2 RATED LOAD & LOWERING RATED LOAD	LIFTING & LOWERING RATED LOAD
under 20	3 months	2 months	1 month
20 - 40	2 months	1 month	2 weeks
40 - 60	1 month	2 weeks	weekly
over 60	consult DEL	consult DEL	consult DEL

Preventive Maintenance

Daily Inspection;

These simple steps should be performed each day, before starting your work. They should be recorded on a Daily Check Chart (see page 47).

Step 1

Run liftgate through its entire cycle daily. Check for any unusual noises coming from the lift mechanism.



Step 2

Inspect liftgate for missing or loosened fasteners, broken welds, signs of overload, hydraulic leaks on the ground and that side platform support chains are well secured.

*Any defects need replacement immediately!
Contact your DEL Liftgate Authorized Service Center.*



Preventive Maintenance

Step 3

Check that all warning decals are in place and legible.
Any missing or damaged decals need replacement immediately.

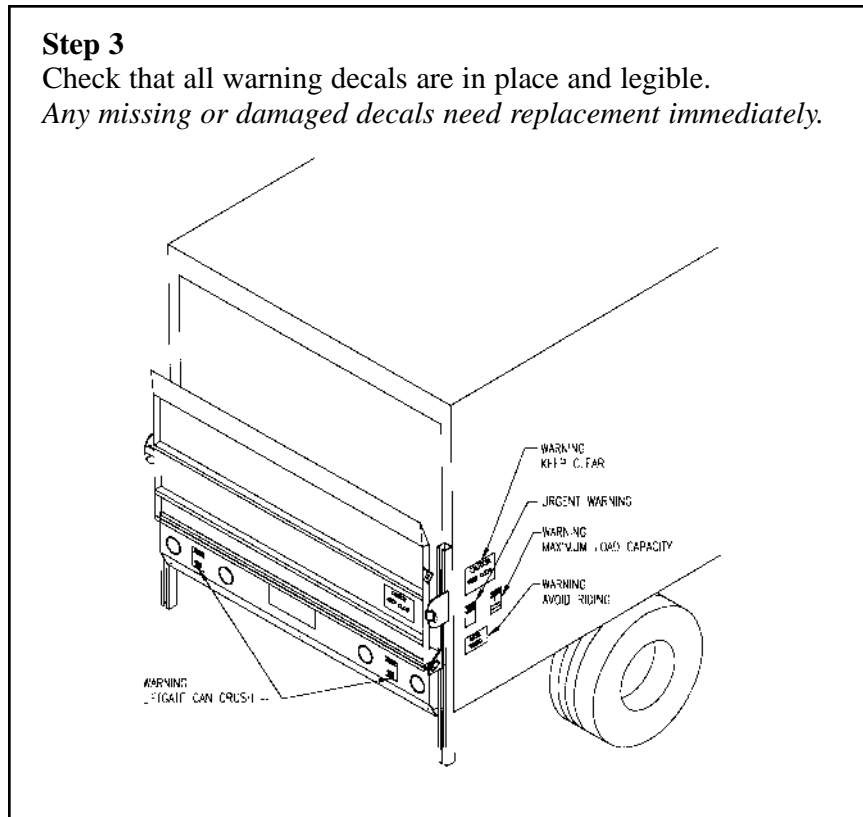

**You may obtain free replacement decals by phoning
the DEL Liftgate Factory at: 1-800-289-1335.
(Have your liftgate model # and serial #)**

NOTE: Please fill out the chart provided, as a reminder that these Steps have been completed daily. You will find a sample of this chart on the page that follows. Contact your employer to receive a copy to keep in your glove compartment.

Preventive Maintenance

Sample Daily Check Chart;

 WARNING
Liftgate may malfunction causing severe personal injury or death. Do not operate the liftgate if everything does not check out properly during the daily inspection. Liftgate must be inspected and repaired IMMEDIATELY by a DEL Liftgate Authorized Service Center.

STEP	Driver's Initials & Date	MS - 8/15/99			
1	Liftgate Cycle Check	OK			
2	Fasteners Check	OK			
2	Welds Check	OK			
2	Signs of Overload Check	OK			
2	Hydraulic Leaks Check	OK			
2	Support Chains Check	OK			
3	Safety Decal Check	OK			

Liftgate Warranty Procedure

Del Liftgates Keeps You On The Job!

With careful maintenance and proper operation your liftgate will provide years of trouble-free service. If a problem does develop, contact the **DEL Liftgates Factory** directly at: **1-800-289-1335** to obtain the name of the DEL Liftgate Authorized Service Center in your area. An Authorized Service Center is trained to service your liftgate.

If you think you have a **WARRANTY CLAIM**, read the following:

- 1) Carefully read the Warranty Registration Form found with your Operating Instructions and Maintenance Manual. All DEL Liftgates are covered by a warranty of 3 years on the mechanical structure and 2 years on the entire liftgate against faulty material and workmanship. Parts and labor are covered for the first year of the warranty. Parts only are covered after one year, and for the remainder of the warranty period.
- 2) Your DEL Liftgate Authorized Service Center will repair your liftgate and get you on the road as quickly as possible. If the problem is warrantable by DEL Liftgates, DEL Liftgates will issue your Authorized Service Center a credit.

Getting Help

Need Help?



If you have questions concerning liftgate installation, maintenance, warranty, parts or operation, contact the DEL Liftgates Factory:

DEL Liftgates, Inc.

190 Lewis Street
Buffalo, NY 1240-6126
Phone: (800) 289-1335
Fax: (716) 854-5424
e-mail: service@liftgate.com
<http://www.liftgate.com>

Keep the name of your local DEL Liftgate Authorized Service Center here for easy access.

NAME:

ADDRESS:

PHONE:

CONTACT PERSON:

Ordering Parts

Genuine OEM Parts

Each DEL Liftgate is manufactured to stringent quality standards for years of reliable service. To ensure maximum performance of your DEL Liftgate, always specify and use genuine OEM replacement parts from DEL Liftgates. For more information on DEL Liftgates OEM Parts, request the Parts Locator Manual.

Same Day Parts Availability

Ask your distributor about our **exclusive “Blue Label™”** same day parts program. Place your order as late as **5:00 p.m. Eastern Time**, specify **“Blue Label™”** service, and we guarantee same day shipment of stocked parts or we pay the freight.

Quick Response **TEAM**

THREE YEAR LIMITED WARRANTY

DEL Liftgates, Inc. (herein called the "Company") warrants to Distributor and/or to original purchaser for use, that it will repair F.O.B. its factory in Buffalo, New York or furnish without charge, freight prepaid, a similar genuine part to replace any part of any liftgate sold (herein called the "Liftgate") by the Company which, within twenty four (24) months after the date of sale by Distributor in the case of hydraulic and electrical parts, and within thirty six (36) months after the date of sale by Distributor in the case of all other parts, is proven to the satisfaction of the Company to have been defective at the time it was sold, provided that all parts claimed defective shall be returned, properly identified, to said factory, freight prepaid. Charges for labor to install such parts shall be paid only with respect to parts which, within twelve (12) months after the date of sale by Distributor, are proven to the satisfaction of the Company to have been defective at the time they were sold and shall be paid in accordance with the Company's Flat Rate Schedule and will be reimbursed at a rate to be set by the Company from time to time. This warranty shall be in effect as of May 1, 1995 and will cover only Liftgates sold after that date. The Company's obligation under this warranty shall not include any costs incurred by anyone for consequential damages in any form and, in particular, without restricting the generality of the foregoing, shall not include costs for vehicle towing, road calls or travel time. This warranty is expressly in lieu of all other warranties, expressed or implied, upon which Liftgates are sold. No other warranty has been made or exists.

This warranty applies only to new and unused Liftgates which, after shipment from said factory, have not been altered, changed, repaired or treated in any manner whatsoever. No warranty of any kind applies to Liftgates, or parts thereof, which have been damaged or have failed because of neglect, lack of maintenance, or service, or lubrication, wear, misuse, overloading, accident, or improper installation. No warranty of any kind, statutory, implied or otherwise, shall apply to second-hand or used Liftgates or to new and unused Liftgates which, after shipment from said factory, have been altered, changes, repaired or treated in any manner whatsoever. The integral parts of the Liftgates not manufactured by the Company are covered only by the standard warranty, if any, of the maker of same and the Company assumes no responsibility with respect thereto. No person has any authority to change this warranty in any manner whatsoever and no attempt to repair or promise to repair or improve, any Liftgate made by any representative of the Company shall waive any provision or term of this warranty, or change or extend this warranty in any manner whatsoever.

No claim under this warranty shall be valid unless such claim is submitted to the Company in writing and received by the Company within thirty six (36) months after date of sale by Distributor or within thirty (30) days after the discovery of the defect which is the basis of such claim, whichever event shall occur first.